

# CorkSport Performance

## GEN-8-42x Valve Cover & Hardware Kit

Mazdaspeed 2.3L Turbo Valve Cover Hardware kit

Written By: Quintin Gunn



 **TOOLS:**

- 10mm Socket - Deep (1)
- 12mm Socket - Deep (1)
- Ratchet Wrench (1)
- 4mm Allen Wrench (1)
- 8mm Socket (1)
- Ratchet Extensions (1)
- Pliers (1)
- Paper Towels (1)

## Step 1 — Getting Started



- First and foremost; **THANK YOU** for becoming a part of the CorkSport Family. We hope to bring you the highest level of Parts, Customer Service, & Support

### **i** How To Use These Instructions

- The instruction format will relate colored markings in the image to the colored dot in the text to the right of the image

## Step 2 — Remove Top Mount Intercooler Cover

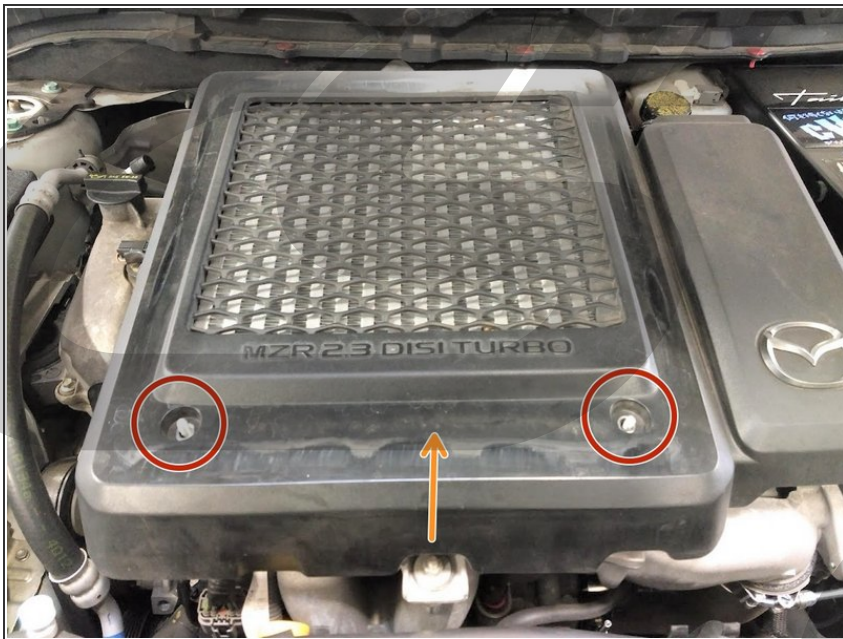

- ⚠** It is best to perform installation when the vehicle is completely cooled

- i** The vehicle shown in this installation guide has various CS parts installed. The processes shown will be similar to OEM parts

- i** If your vehicle is equipped with a Front Mount Intercooler, you may skip to step 4

- Remove the QTY(2) 10mm nuts from the Intercooler Cover
- Gently pull up on the Intercooler cover from the front of the vehicle and remove

### Step 3 — Remove Bypass Valve Hoses



- Gently pull the small vacuum line from the Bypass Valve and tuck out of the way
- Using a pair of **Pliers**, compress the large Bypass Valve hose clamp and remove the hose from the Bypass Valve

## Step 4 — Remove Top Mount Intercooler



- Using a **10mm Deep Socket and Ratchet**, loosen the QTY(2) hose clamps indicated at the Intercooler connection points
- With a **12mm Socket and Ratchet**, remove the QTY(3) indicated nuts holding the Intercooler in place
- Gently pull upward on the Intercooler to clear the studs, then pull in the direction indicated to remove from the vehicle

## Step 5 — Remove Wiring Harness Connections - Part 1

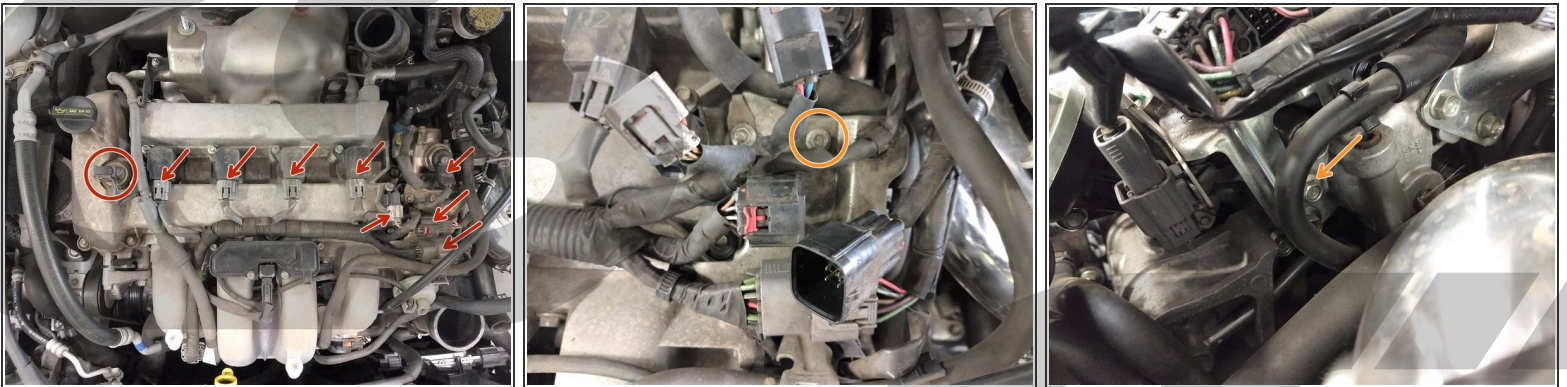

- Disconnect the Negative Battery terminal
- Disconnect the indicated electrical connectors
- Using an **8mm Socket and Ratchet**, remove the QTY(2) bolts from the Wiring Harness Bracket

## Step 6 — Remove Wiring Harness Connections - Part 2

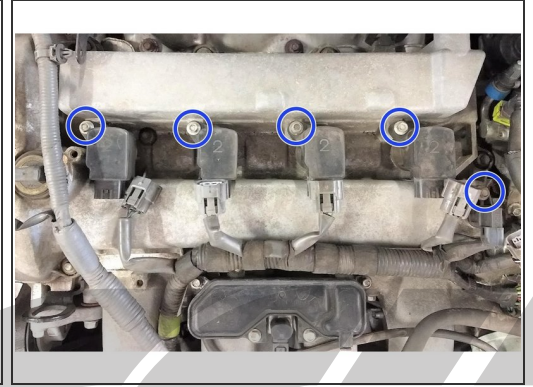
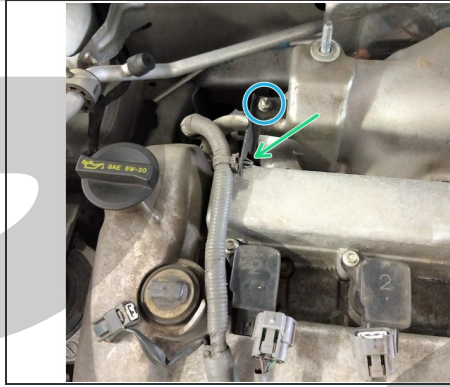
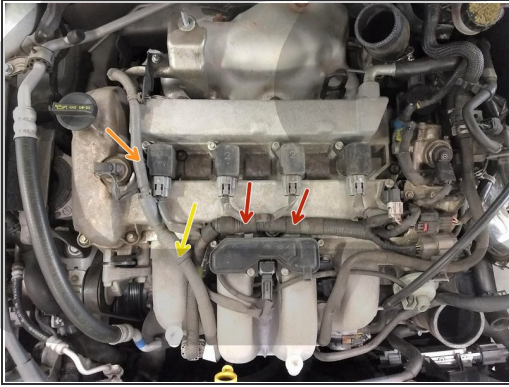

- Grab the wiring harness at the indicated location and gently wiggle back-and-forth while pulling up to release the plastic tabs
- ⓘ This wiring harness should now be free enough to access the Valve Cover bolts underneath
- Grab the wiring harness at the indicated location and gently wiggle back-and-forth while pulling up to release the plastic tab
- Grab the wiring harness at the indicated location and gently wiggle back-and-forth while pulling up to release the plastic tab
- Using a pair of **Pliers**, remove the plastic clip holding the Wiring Harness to the bracket
- Using a **10mm Socket and Ratchet**, remove the bracket from the vehicle
- Unbolt the QTY(4) Ignition Coils and Camshaft Position Sensor with an **8mm Socket and Ratchet**
- Remove the QTY(4) Ignition Coils and Camshaft Position Sensor from the vehicle

## Step 7 — Remove the Valve Cover

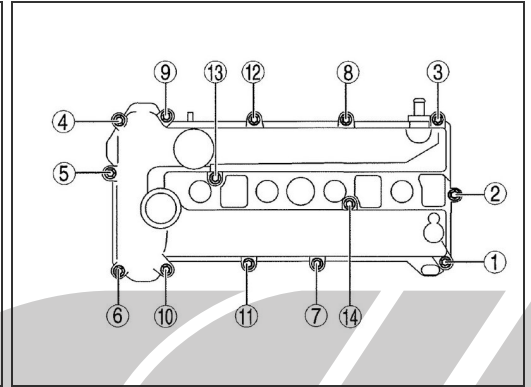
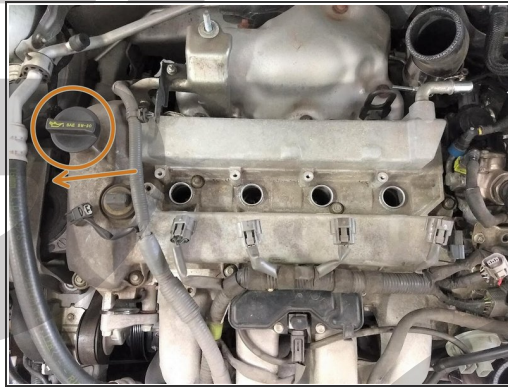
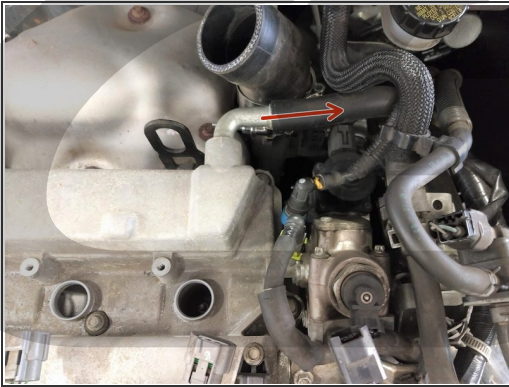

- Remove the Vacuum hose by gently pulling in the indicated direction
  - Remove the Oil Filler Cap and gently slide the wiring harness over the Oil Filler hole and tuck to the side
- ⚠ Before continuing, Vacuum and remove any loose debris from the Valve Cover and the edge of the Cylinder Head to prevent debris entering the engine**
- With an **8mm Socket and Ratchet**, unbolt the Valve Cover in the order indicated
    - ⚠ Failure to follow this order may warp the Cylinder Head**
  - Gently remove the Valve Cover from the vehicle
    - ⓘ To prevent gasket damage while off the vehicle, place a paper towel or cloth on a workbench before setting the Valve Cover gasket-side-down
    - ⓘ While the Valve Cover is off of the engine, place paper towels or other cloth over the exposed Cylinder Head to prevent debris entering the engine

## Step 8 — Prepare Valve Cover - Reusing original Valve Cover

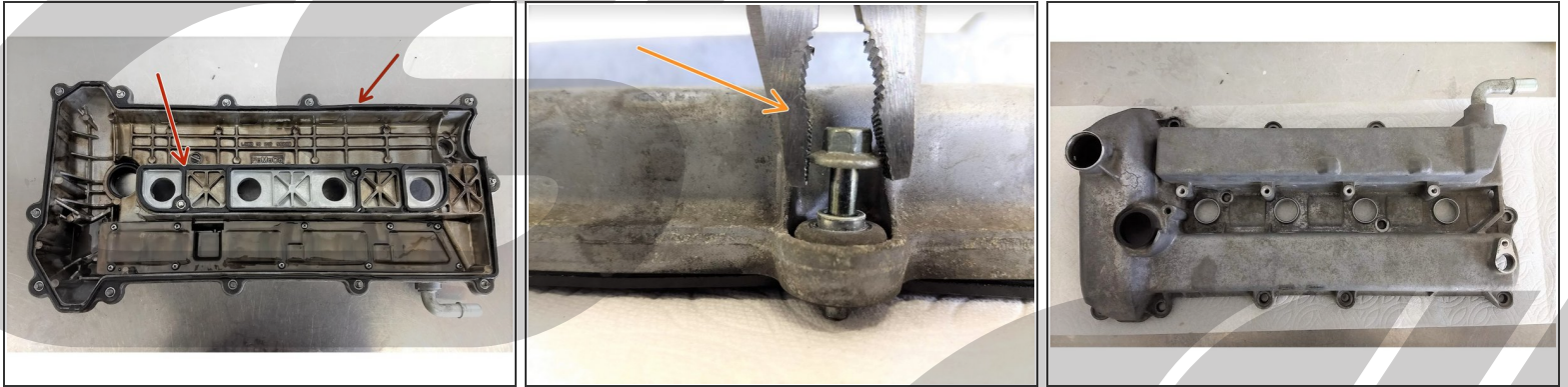

- Inspect Valve Cover gaskets for rips, tears, or damage
  - ⚠ If rips, tears, or damage is found, replace the gasket
  - ⓘ Mazda OEM Gasket part number: **L3K9-10-230**
- With the Valve Cover topside-up and on a paper towel, pull the QTY(14) bolts from the Valve Cover with a pair of **Pliers** as shown
  - ⓘ All bolts are captive, so the bolt will come out with the spacer and rubber bushing as well
- ⓘ With the Valve Cover out of the vehicle, now is a great time for a good cleaning (or painting/powdercoat)!



## Step 9 — Prepare Valve Cover - New Valve Cover from CS kit

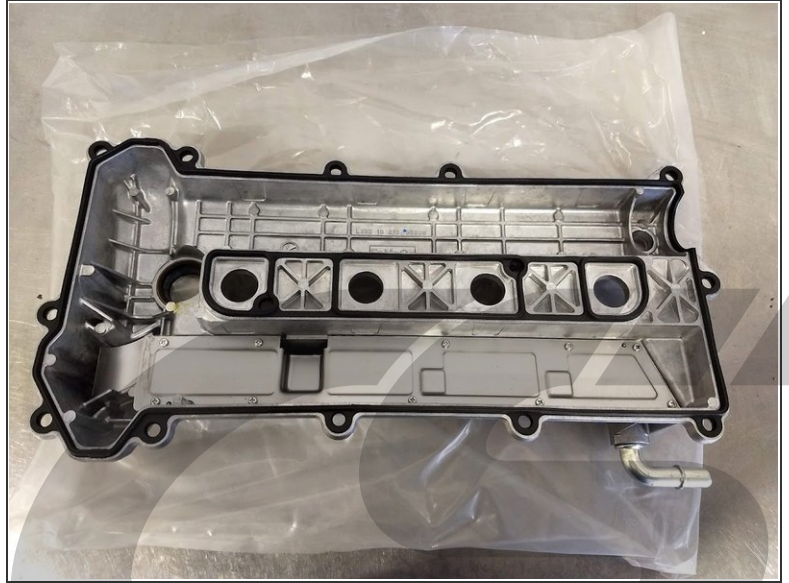

- ⓘ If you are using a new Valve Cover, it comes pre-fitted with all gaskets and seals required
  - Inspect the included gaskets for alignment and reposition if necessary

## Step 10 — Insert new hardware into Valve Cover

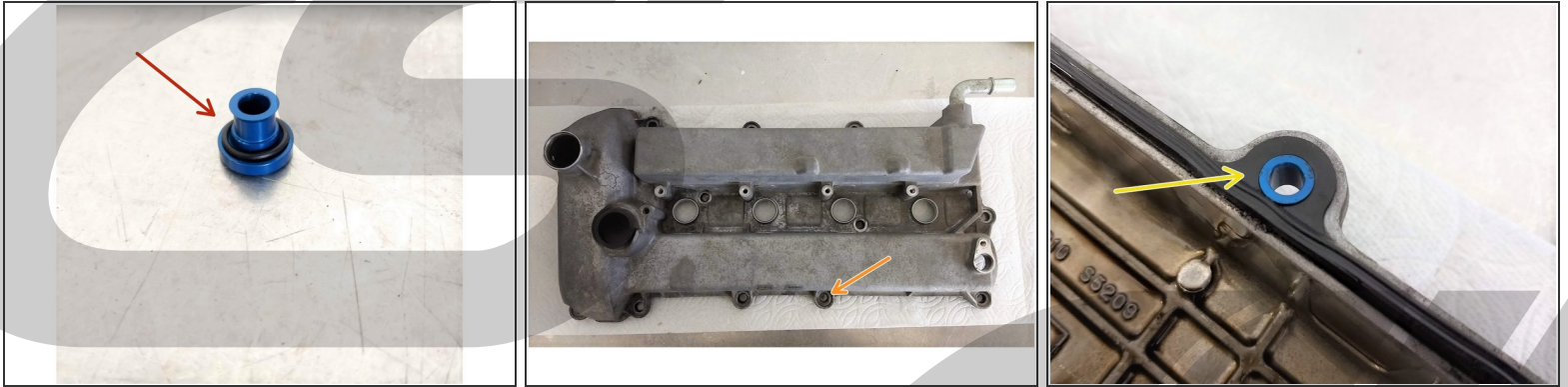

- Place an o-ring around the Colored Spacer as shown
- ⓘ Do not worry about seating the o-ring into the groove. The o-ring will naturally seat when tightened. Keep o-ring centered as best as possible when handling
- Insert the spacer into the Valve Cover at one of the holes left by the hardware removed earlier
- On the underside of the Valve Cover, push the gasket around the bottom lip of the spacer so as to be retained
- Repeat for all QTY(14) locations

## Step 11 — Install new Valve Cover

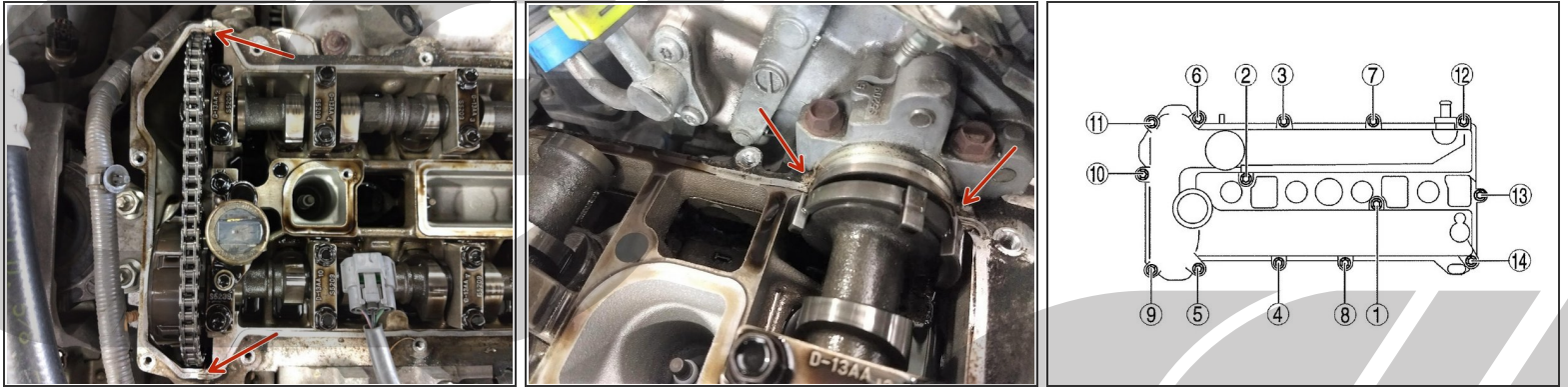

- Clean the mating surface of the Cylinder Head by wiping with a paper towel and clearing any debris or remnants of old gasket or gasket maker/silicone sealant
- Apply silicone sealant gasket maker to the mating face in the locations shown
- Gently lower the Valve Cover onto the Cylinder Head, being sure the bolt holes are aligned
- Insert and hand-tighten the provided QTY(14) M6 Countersunk bolts into indicated locations using a **4mm Allen Wrench**
  - Tighten to 71-84 in\*lbf (6-7 ft\*lbf) (8-9.5 Nm) in the order shown

**⚠ Failure to follow this pattern may warp the Cylinder Head**

## Step 12 — Reassemble the Vehicle

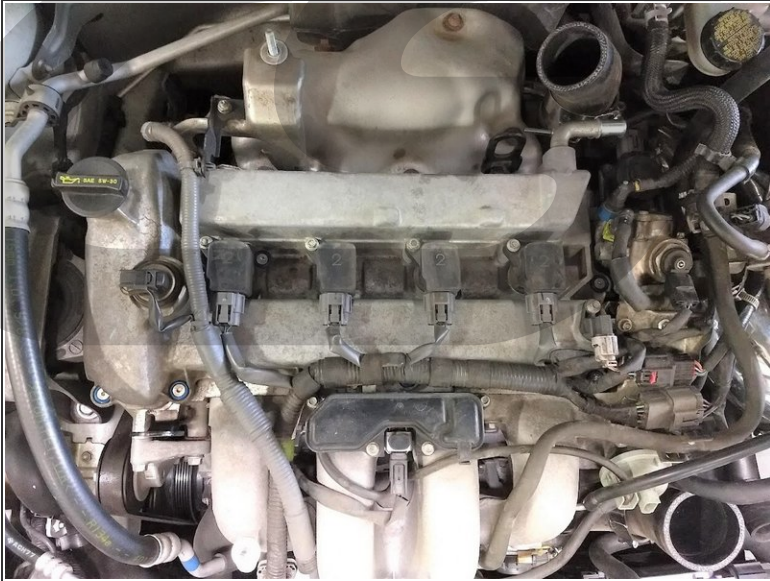

- Move the wiring harness back over the Valve Cover and into its original position
- Reinstall the brackets holding the wiring harnesses in place
- Reinsert the plastic clips retaining the wiring harnesses
- Reinsert and install the QTY(4) Ignition Coils
  - With an **8mm Socket and Ratchet**, tighten to 54-84 in\*lb (62-96 kgf\*-cm, or 6.0-9.5 Nm)
- Reinstall the Oil Filler Cap and Camshaft Position Sensor
- Reconnect all electrical connectors
- Reinstall the Bypass Valve hoses, Top Mount Intercooler, and Intercooler Cover

## Step 13 — Post-Installation Checks



**⚠ Before starting the vehicle, wait 24 hours for the Silicone Sealant to dry**

- After starting the vehicle, check for:
  - Oil leaks around the Valve Cover mating face
  - Air leaks from the Intercooler connection points
  - Air leaks from the PCV Vacuum hose
- Go for a drive and check oil temps and pressures to ensure a proper reinstallation

## Step 14 — Installation Complete



- This completes your installation of the CorkSport Valve Cover Hardware!
- Contact us with any questions or concerns at [sales@corksport.com](mailto:sales@corksport.com) or (360) 260-2675.
- Share your experience using #CorkSport on Instagram, Facebook, and Twitter.